

PSM 220 / 330 DM



YARI OTOMATİK ÇİFT YÖN AÇILI TESTERE TEZGAHI SEMI AUTOMATIC DOUBLE MITER BANDSAW MACHINE



01
MALZEME SIKMA SİSTEMİ
MATERIAL CLAMPING SYSTEM

02
AÇI SABİTLEME
FIXING MITER DEGREE

03
KUMANDA PANELİ
CONTROL PANEL

04
DÖNER GÖBEK SİSTEMİ
MITER CUTTING

ÖLÇÜLER DIMENSIONS

MAFSALLI MODELLER PIVOT TYPES

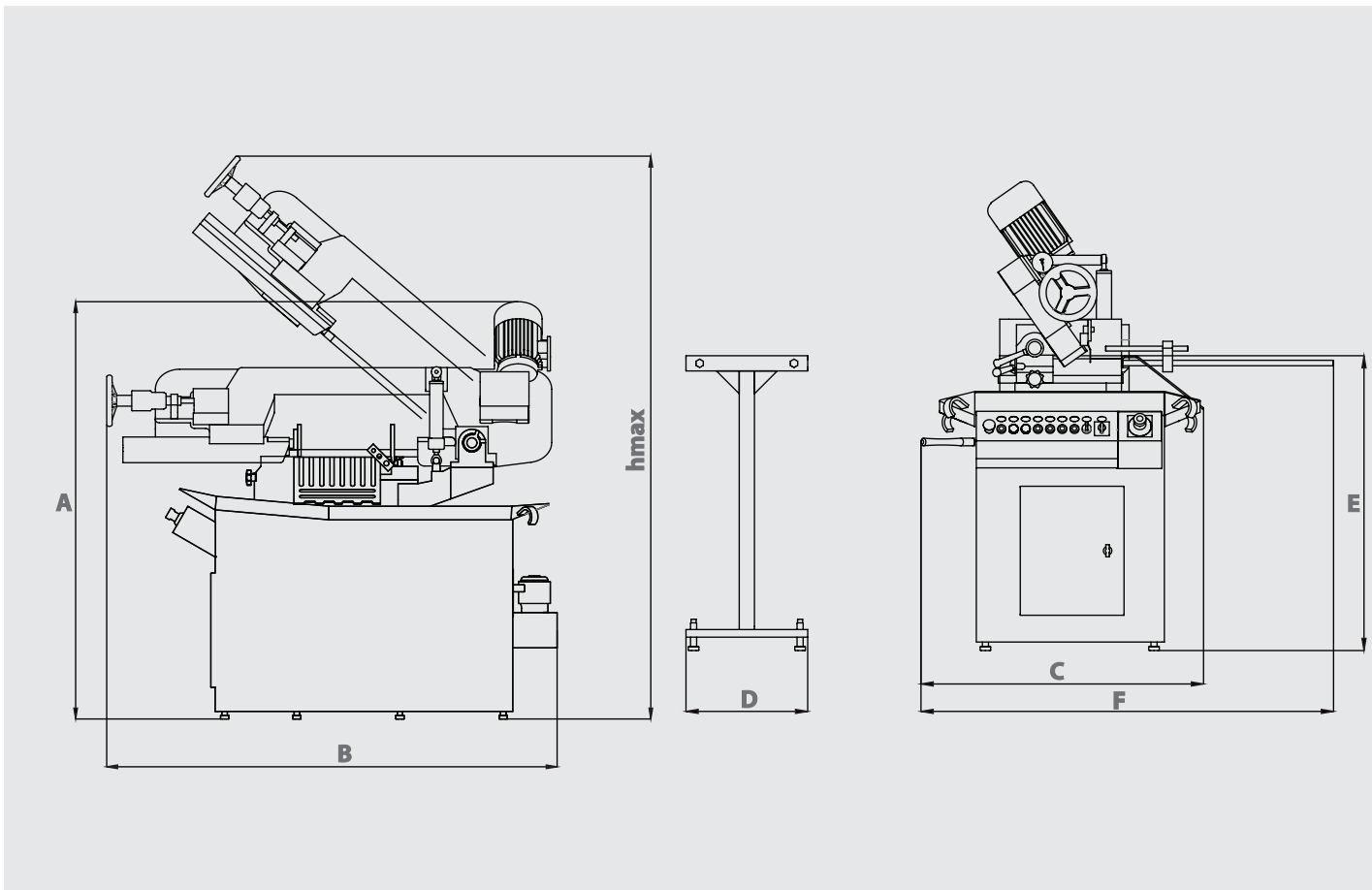

TEKNİK ÖZELLİKLER TECHNICAL FEATURES

| | | | | | | | | | | | | | |
|---|-----------------------|---|-----------------------|---|-----------------------|---|----------------------|---|----------------------|---|-----------------------|------|-----------------------|
| A | 1545 mm 60.83 inch | B | 1780 mm 70.08 inch | C | 1030 mm 40.55 inch | D | 400 mm 15.75 inch | E | 970 mm 38.19 inch | F | 1470 mm 57.87 inch | hmax | 2060 mm 81.10 inch |
|---|-----------------------|---|-----------------------|---|-----------------------|---|----------------------|---|----------------------|---|-----------------------|------|-----------------------|

| | | | |
|---|---|---|---|
| Yarı Otomatik Semi Automatic | Şerit Ölçüsü Blade Dimension 27 x 0.9 x 3175 mm 1 x 0.035 x 125 inch | kW Şerit Motoru Blade Motor 1.1 kW - 1000 d/dk 1.47 kW - 1000 rpm | kW Sürücü Motor Feeding Motor Manuel Manual |
| kW Hidrolik Motor Hydraulic Pump Motor 0.25 kW - 1500 d/dk 0.34 hp - 1500 rpm | kW H ₂ O Soğutucu Motor Cooling Liquid Motor 0.12 kW 3000 d/dk 0.16 hp - 3000 rpm | Voltaj Voltage 400 V 400 V | Maksimum Güç Maximum Power 1.47 kW 1.97 hp |
| Kesme Hızı Cutting Speed 25 m/dk - 82 ft/min 100 m/dk - 328 ft/min | KG LBS Ağırlık Weight 500 kg 1102 lbs | Malzeme Sıkma Sistemi Material Clamping System Manuel Manual | Şerit Germe Sistemi Blade Tensioning System Pnömatik Pneumatic |

| Kesim Kapasitesi Cutting Capacity | | mm inch | 60° | 45° | 30° | 0° | 30° | 45° | 60° |
|--------------------------------------|----------------------|------------|----------------------------------|----------------------------------|-----------------------------------|----------------------------------|----------------------------------|----------------------------------|--------------------------------|
| 220 mm 8.66 inch | 330 mm 12.99 inch | ● | 200 mm 7.87 inch | 220 mm 8.66 inch | 220 mm 8.66 inch | 220 mm 8.66 inch | 220 mm 8.66 inch | 180 mm 7.08 inch | 100 mm 3.93 inch |
| 220 mm 8.66 inch | 330 mm 12.99 inch | ■ | 175 x 175 mm 6.89 x 6.89 inch | 220 x 220 mm 8.66 x 8.66 inch | 220 x 220 mm 8.66 x 8.66 inch | 220 x 220 mm 8.66 x 8.66 inch | 220 x 220 mm 8.66 x 8.66 inch | 180 x 180 mm 7.08 x 7.08 inch | 90 x 90 mm 3.54 x 3.54 inch |
| 220 mm 8.66 inch | 330 mm 12.99 inch | □ | 200 x 160 mm 7.87 x 6.30 inch | 220 x 230 mm 8.66 x 9.05 inch | 220 x 330 mm 8.66 x 12.99 inch | 220 x 230 mm 8.66 x 9.05 inch | 220 x 230 mm 8.66 x 9.05 inch | 210 x 180 mm 8.27 x 7.08 inch | 90 x 90 mm 3.54 x 3.54 inch |