

PAR 350 M

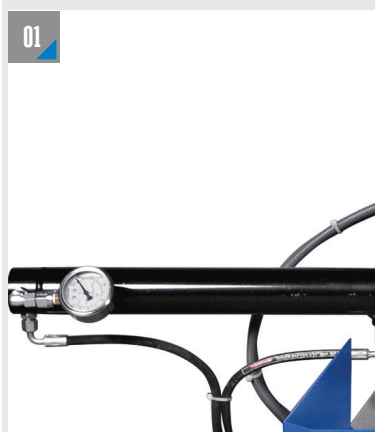

TAM OTOMATİK AÇILI TESTERE TEZGAHI FULL AUTOMATIC MITER BANDSAW MACHINE



MALZEME SIKMA SİSTEMİ
MATERIAL CLAMPING SYSTEM



MALZEME SÜRME SİSTEMİ
MATERIAL FEEDING SYSTEM

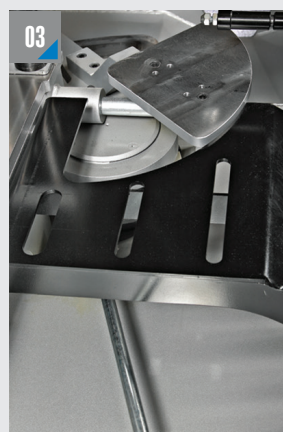

AÇI KİLİTLEME
MITER FIXING

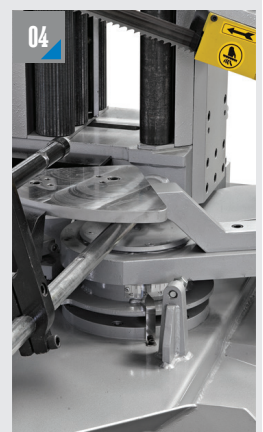

DÖNER GÖBEK SİSTEMİ
MITER CUTTING

ÖLÇÜLER DIMENSIONS

MAFSALLI MODELLER PIVOT TYPES

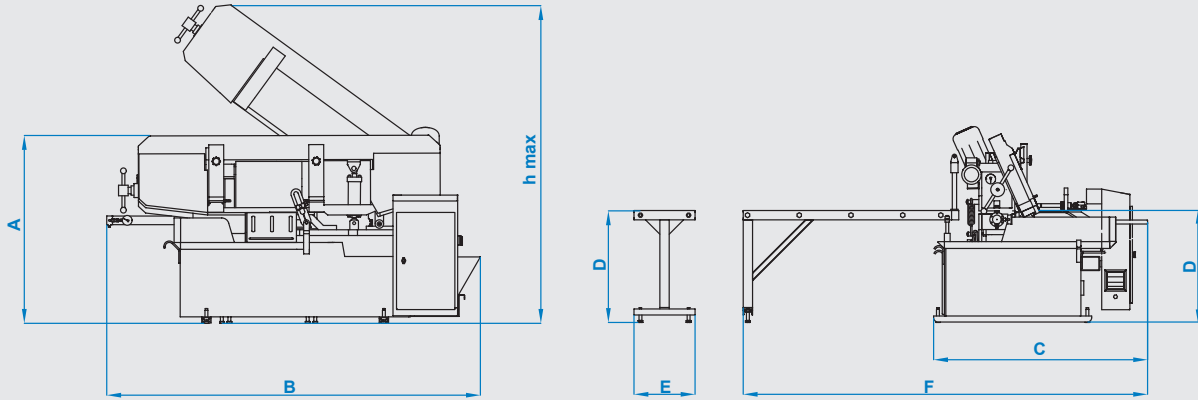

TEKNİK ÖZELLİKLER / TECHNICAL FEATURES

| | | | | | | | | | | | | | |
|---|-----------------------|---|------------------------|---|-----------------------|---|----------------------|---|----------------------|---|------------------------|------|-----------------------|
| A | 1370 mm 53.94 inch | B | 2600 mm 102.36 inch | C | 1480 mm 58.27 inch | D | 775 mm 30.51 inch | E | 525 mm 20.67 inch | F | 2800 mm 110.24 inch | hmax | 2150 mm 84.65 inch |
|---|-----------------------|---|------------------------|---|-----------------------|---|----------------------|---|----------------------|---|------------------------|------|-----------------------|

| | | | | | | | |
|--|--|--|---|--|--|--|---|
| | Yarı Otomatik Semi Automatic | | Şerit Ölçüsü Blade Dimension 34 x 1.1 x 4570 mm 1 1/4 x 0.042 x 180 inch | | Şerit Motoru Blade Motor 4 kW - 1500 d/d 5.36 hp - 1500 rpm | | Sürücü Motor Feeding Motor 0.25 kW - 1500 d/d 0.33 hp - 1500 rpm |
| | Hidrolik Motor Hydraulic Pump Motor 0.75 kW - 1400 d/dk 1 hp - 1500 rpm | | Soğutucu Motor Cooling Liquid Motor 0.12 kW - 3000 d/dk 0.16 hp - 3000 rpm | | Voltaj Voltage 400 V 400 V | | Maksimum Güç Maximum Power 5.12 kW 6.86 hp |
| | Kesme Hızı Cutting Speed 15 m/dk - 115 m/dk 100 m/dk - 230 ft/min | | Ağırlık Weight 1150 kg 2335 lbs | | Malzeme Sıkma Sistemi Material Clamping System Hidrolik Hydraulic | | Şerit Germe Sistemi Blade Tensioning System Hidromekanik Hydramechanic |

| | | | | | | | | | | | | |
|------------------------------------|--------------------------------------|-----------------------------------|--------------------------------------|----------------------|----------------------|----------------------|----------------------|----------------------|----------------------|----------------------|------------------------------------|-----------------------------------|
| | Kesim Kapasitesi Cutting Capacity | | Kesim Kapasitesi Cutting Capacity | | mm inch | | | | | | | |
| 350 mm 13.78 inch | 460 mm 18.11 inch | 350 mm 13.78 inch | 350 mm 13.78 inch | 350 mm 13.78 inch | 350 mm 13.78 inch | 350 mm 13.78 inch | 350 mm 13.78 inch | 320 mm 12.60 inch | 350 mm 13.78 inch | 350 mm 13.78 inch | 300 x 300 mm 11.81 x 11.81 inch | 320 x 180 mm 12.60 x 7.09 inch |
| 350 x 350 mm 13.78 x 13.78 inch | 350 x 460 mm 13.78 x 18.11 inch | 250 x 400 mm 9.84 x 15.75 inch | 320 x 180 mm 12.60 x 7.09 inch | | | | | | | | | |