

PSM 440 / 700 DM

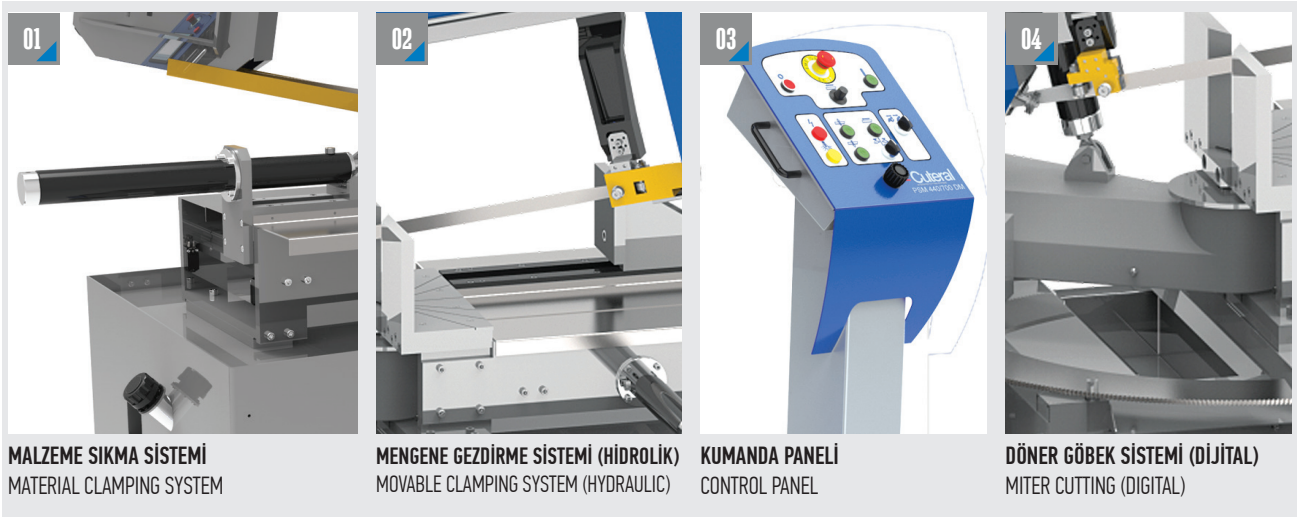

YARI OTOMATİK ÇİFT YÖN AÇILI TESTERE TEZGAHI SEMI AUTOMATIC DOUBLE MITER BANDSAW MACHINE



ÖLÇÜLER DIMENSIONS

MAFSALLI MODELLER PIVOT TYPES

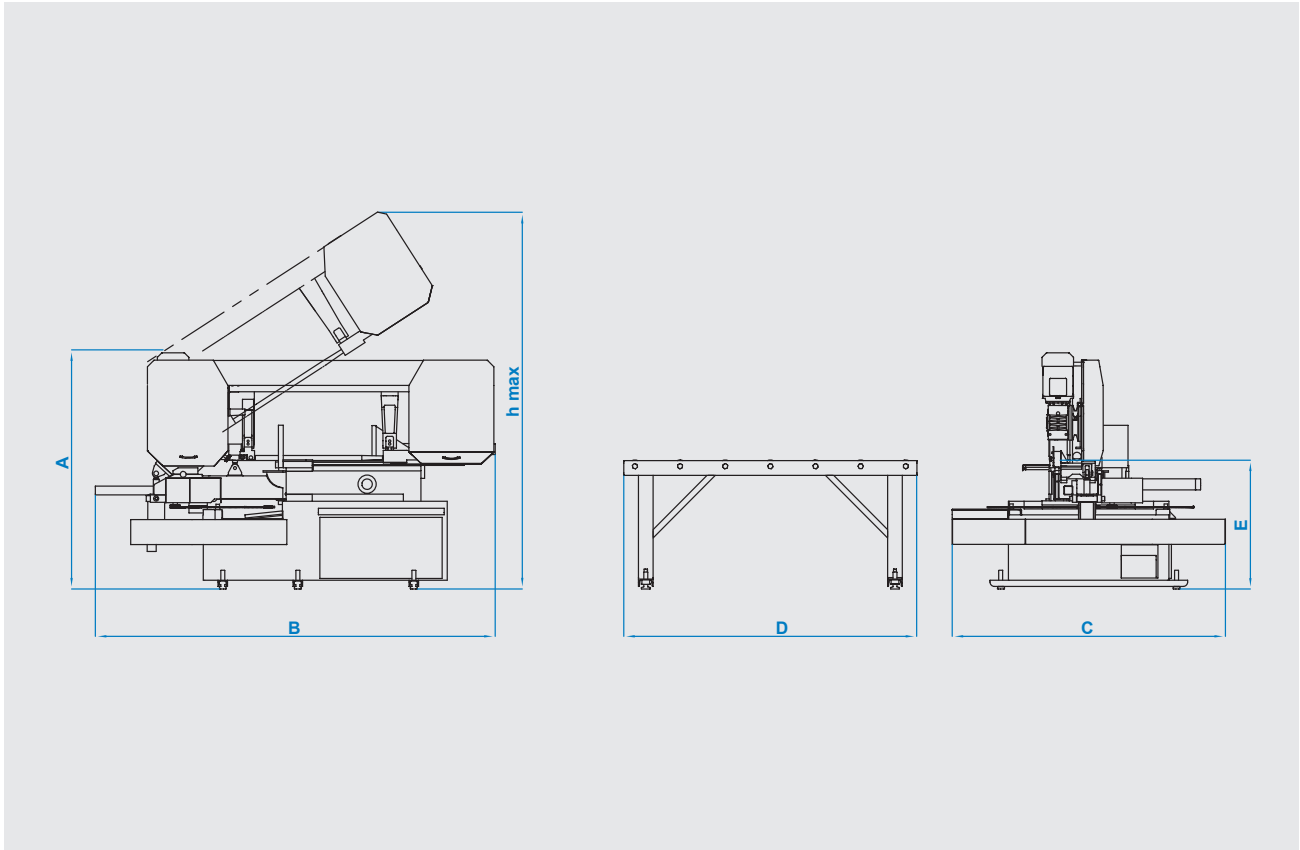

TEKNİK ÖZELLİKLER / TECHNICAL FEATURES

A	1680 mm 66.14 inch	B	2800 mm 110.24 inch	C	1870 mm 73.62 inch	D	1980 mm 77.95 inch	E	950 mm 37.40 inch	hmax	2690 mm 105.91 inch
---	-----------------------	---	------------------------	---	-----------------------	---	-----------------------	---	----------------------	------	------------------------

Yarı Otomatik Semi Automatic	Şerit Ölçüsü Blade Dimension 41 x 1.3 x 5270 mm 1 1/2 x 0.050 x 207.5 inch	Şerit Motoru Blade Motor 4 kW - 1500 d/d 5.36 hp - 1500 rpm	Sürücü Motor Feeding Motor Manuel Manual
Hidrolik Motor Hydraulic Pump Motor 0.75 kW - 1400 d/dk 0.5 hp - 1400 rpm	Soğutucu Motor Cooling Liquid Motor 0.12 kW - 3000 d/dk 0.16 hp - 3000 rpm	Voltaj Voltage 400 V 400 V	Maksimum Güç Maximum Power 4.87 kW 6.53 hp
Kesme Hızı Cutting Speed 15 m/dk - 100 m/dk 49 m/dk - 328 ft/min	Ağırlık Weight 1750 kg 3800 lbs	Malzeme Sıkma Sistemi Material Clamping System Hidrolik Hydraulic	Şerit Germe Sistemi Blade Tensioning System Hidromekanik Hydramechanic

90°		mm inch	60°	45°	30°	0°	15°	45°	60°
Kesim Kapasitesi Cutting Capacity	Kesim Kapasitesi Cutting Capacity	●	340 mm 13.38 inch	440 mm 17.32 inch	440 mm 17.32 inch	440 mm 17.32 inch	440 mm 17.32 inch	440 mm 17.32 inch	340 mm 13.38 inch
440 mm 17.32 inch	700 mm 27.55 inch	■	330 mm 12.99 inch	430 mm 16.92 inch	440 mm 17.32 inch	440 mm 17.32 inch	440 mm 17.32 inch	430 mm 16.92 inch	330 mm 12.99 inch
		■	330 x 330 mm 12.99 x 12.99 inch	380 x 500 mm 14.96 x 19.68 inch	440 x 600 mm 17.32 x 23.62 inch	440 x 700 mm 17.32 x 27.55 inch	440 x 600 mm 17.32 x 23.62 inch	380 x 500 mm 14.96 x 19.68 inch	330 x 330 mm 12.99 x 12.99 inch