

PAR 300 M



TAM OTOMATİK AÇILI TESTERE TEZGAHI FULL AUTOMATIC MITER BANDSAW MACHINE



MALZEME SIKMA SİSTEMİ
MATERIAL CLAMPING SYSTEM



MALZEME SÜRME SİSTEMİ
MATERIAL FEEDING SYSTEM



AÇI KİLİTLEME
MITER FIXING

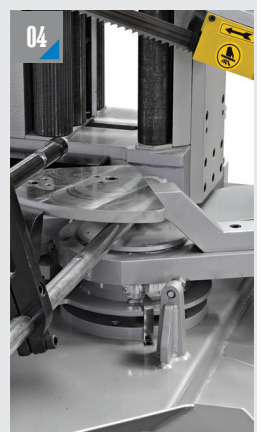

DÖNER GÖBEK SİSTEMİ
MITER CUTTING

ÖLÇÜLER DIMENSIONS

MAFSALLI MODELLER PIVOT TYPES

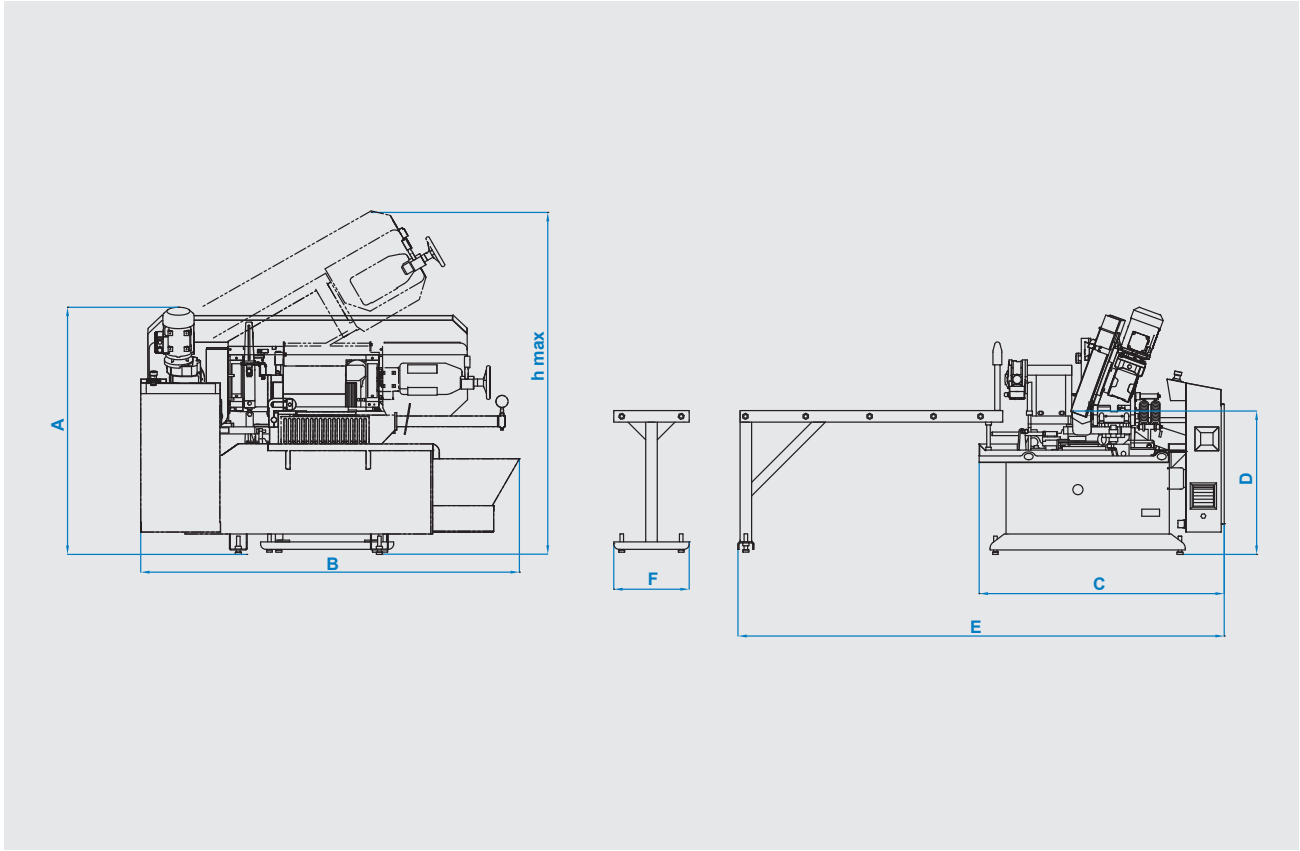

TEKNİK ÖZELLİKLER / TECHNICAL FEATURES

A	1392 mm 54.80 inch	B	2120 mm 83.46 inch	C	1415 mm 55.71 inch	D	810 mm 31.89 inch	E	2740 mm 107.87 inch	F	425 mm 16.73 inch	hmax	2010 mm 79.13 inch
---	-----------------------	---	-----------------------	---	-----------------------	---	----------------------	---	------------------------	---	----------------------	------	-----------------------

Otomatik Automatic	Şerit Ölçüsü Blade Dimension 27 x 0.9 x 3970 mm 1 x 0.035 x 156.3 inch	Şerit Motoru Blade Motor 1.5 kW - 1500 d/d 2 hp - 1500 rpm	Sürücü Motor Feeding Motor 0.25 kW - 1500 d/d 0.33 hp - 1500 rpm
Hidrolik Motor Hydraulic Pump Motor 0.75 kW - 1400 d/dk 1 hp - 1400 rpm	Soğutucu Motor Cooling Liquid Motor 0.12 kW - 3000 d/dk 0.16 hp - 3000 rpm	Voltaj Voltage 400 V 400 V	Maksimum Güç Maximum Power 2.62 kW 3.51 hp
Kesme Hızı Cutting Speed 15 m/dk - 100 m/dk 49 m/dk - 462 ft/min	Ağırlık Weight 1000 kg 2204 lbs	Malzeme Sıkma Sistemi Material Clamping System Hidrolik Hydraulic	Şerit Germe Sistemi Blade Tensioning System Hidromekanik Hydramechanic

90°		mm inch	60°	45°	30°	0°	30°	45°	60°
Kesim Kapasitesi Cutting Capacity	Kesim Kapasitesi Cutting Capacity	●	170 mm 6.69 inch	270 mm 10.62 inch	300 mm 11.81 inch	300 mm 11.81 inch			
300 mm 11.81 inch	340 mm 13.39 inch	■	160 mm 6.29 inch	220 mm 8.66 inch	220 mm 8.66 inch	220 mm 8.66 inch			
		■	110 x 170 mm 4.33 x 6.69 inch	170 x 270 mm 6.69 x 10.62 inch	220 x 300 mm 8.66 x 11.81 inch	220 x 340 mm 8.66 x 13.38 inch			