

PAR 280



TAM OTOMATİK TESTERE TEZGAHI FULL AUTOMATIC BANDSAW MACHINE







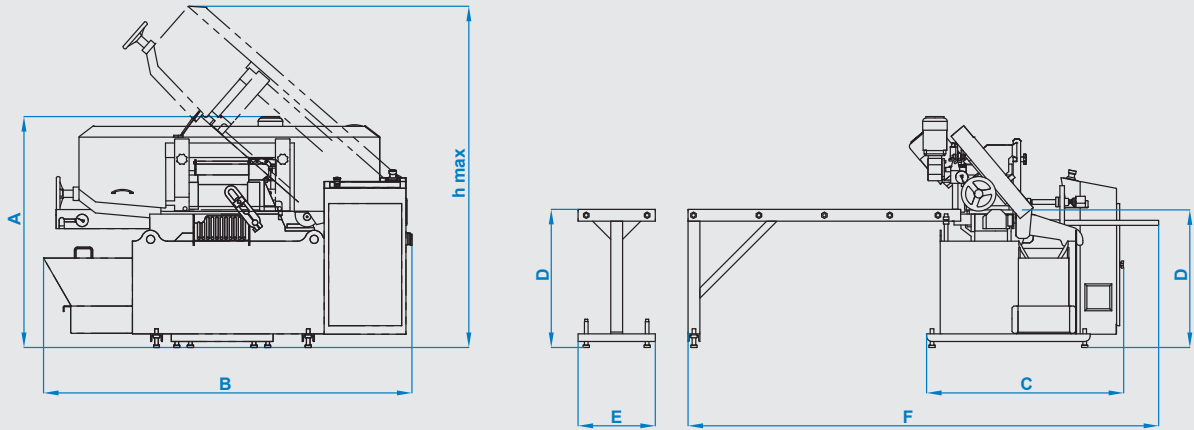







ÖLÇÜLER DIMENSIONS









MAFSALLI MODELLER PIVOT TYPES



TEKNİK ÖZELLİKLER / TECHNICAL FEATURES

A	1235 mm 48.62 inch	B	2030 mm 79.92 inch	C	1180 mm 46.46 inch	D	725 mm 28.54 inch	E	425 mm 16.73 inch	F	2590 mm 101.97 inch	hmax	1880 mm 74.02 inch
---	-----------------------	---	-----------------------	---	-----------------------	---	----------------------	---	----------------------	---	------------------------	------	-----------------------

 Otomatik Automatic	 Şerit Ölçüsü Blade Dimension 27 x 0.9 x 3670 mm 1 x 0.035 x 144.5 inch	 Şerit Motoru Blade Motor 1.5 kW - 1500 d/d 2 hp - 1500 rpm	 Sürücü Motor Feeding Motor 0.25 kW - 1500 d/d 0.33 hp - 1500 rpm
 Hidrolik Motor Hydraulic Pump Motor 0.75 kW - 1400 d/dk 1 hp - 1400 rpm	 Soğutucu Motor Cooling Liquid Motor 0.12 kW - 3000 d/dk 0.16 hp - 3000 rpm	 Voltaj Voltage 400 V 400 V	 Maksimum Güç Maximum Power 2.62 kW 3.51 hp
 Kesme Hızı Cutting Speed 15 m/dk - 100 m/dk 130 m/dk - 426 ft/min	 Ağırlık Weight 620 kg 1367 lbs	 Malzeme Sıkma Sistemi Material Clamping System Hidrolik Hydraulic	 Şerit Germe Sistemi Blade Tensioning System Hidromekanik Hydramechanic

 Kesim Kapasitesi Cutting Capacity	 Kesim Kapasitesi Cutting Capacity	mm inch	 60°	 45°	 30°	 0°	 30°	 45°	 60°
280 mm 11.02 inch	290 mm 11.42 inch					280 mm 11.02 inch			
						250 x 250 mm 9.84 x 9.84 inch			
						150 x 290 mm 5.91 x 11.42 inch			