

CSM 550 / 800 DM

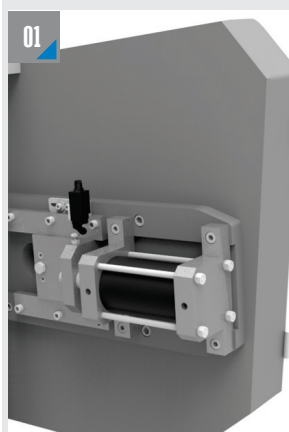

YARI OTOMATİK ÇİFT YÖN AÇILI HİDROLİK SÜTUNLU TESTERE TEZGAHI DOUBLE MITER SEMI AUTOMATIC DOUBLE COLUMN HYDRAULIC BANDSAW MACHINE



ŞERİT GİRDİRME SİSTEMİ
BLADE TENSIONING



MALZEME SÜRME SİSTEMİ
MATERIAL FEEDING SYSTEM



MALZEME SIKMA SİSTEMİ
MATERIAL CLAMPING SYSTEM



AÇILI KESİM
MITER CUTTING

ÖLÇÜLER DIMENSIONS

SÜTUNLU MODELLER DOUBLE COLUMN TYPES

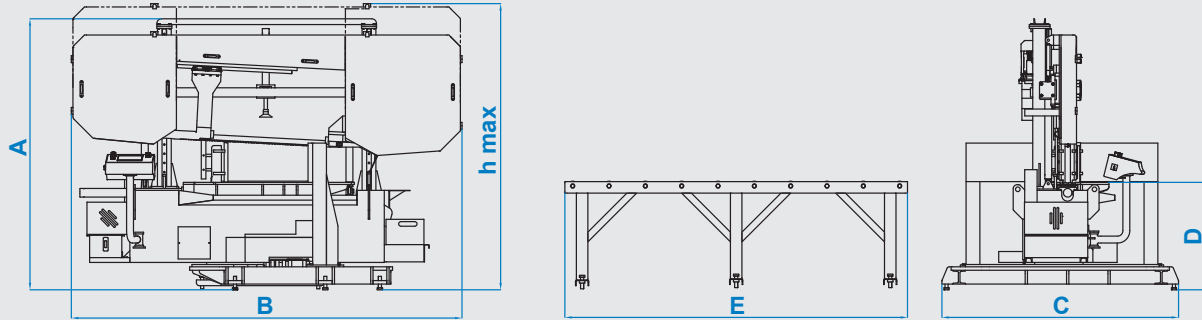

TEKNİK ÖZELLİKLER / TECHNICAL FEATURES

A	2360 mm 92.91 inch	B	3400 mm 133.86 inch	C	2060 mm 81.10 inch	D	935 mm 36.81 inch	E	3000 mm 118.11 inch	hmax	2490 mm 98.03 inch
---	-----------------------	---	------------------------	---	-----------------------	---	----------------------	---	------------------------	------	-----------------------

Yarı Otomatik Semi Automatic	Şerit Ölçüsü Blade Dimension 54 x 1.6 x 7240 mm 1.614 x 0.051 x 269.6 inch	Şerit Motoru Blade Motor 4 kW - 1500 d/d 5.36 hp - 1500 rpm	Sürücü Motor Feeding Motor Manuel Manual
Hidrolik Motor Hydraulic Pump Motor 1.1 kW - 1500 d/dk 1.48 hp - 1500 rpm	Soğutucu Motor Cooling Liquid Motor 0.12 kW - 3000 d/dk 0.16 hp - 3000 rpm	Voltaj Voltage 400 V 400 V	Maksimum Güç Maximum Power 5.97 kW 8 hp
Kesme Hızı Cutting Speed 15 m/dk - 100 m/dk 49 m/dk - 328 ft/min	Ağırlık Weight 3500 kg 7716 lbs	Malzeme Sıkma Sistemi Material Clamping System Hidrolik Hydraulic	Şerit Germe Sistemi Blade Tensioning System Hidrolik Hydraulic

Kesim Kapasitesi Cutting Capacity		Kesim Kapasitesi Cutting Capacity		mm inch	60°	45°	30°	0°	15°	45°	60°
550 mm 21.65 inch	800 mm 31.49 inch	500 mm 19.68 inch	500 mm 19.68 inch	500 mm 19.68 inch	500 mm 19.68 inch	550 mm 21.65 inch	550 mm 21.65 inch	550 mm 21.65 inch	550 mm 21.65 inch	500 mm 19.68 inch	300 mm 11.81 inch
550 mm 21.65 inch	800 mm 31.49 inch	500 mm 19.68 inch	500 mm 19.68 inch	500 mm 19.68 inch	550 mm 21.65 inch	550 mm 21.65 inch	550 mm 21.65 inch	550 mm 21.65 inch	550 mm 21.65 inch	500 mm 19.68 inch	300 mm 11.81 inch
550 mm 21.65 inch	800 mm 31.49 inch	500 mm 19.68 inch	500 mm 19.68 inch	500 mm 19.68 inch	550 mm 21.65 inch	550 mm 21.65 inch	550 mm 21.65 inch	550 mm 21.65 inch	550 mm 21.65 inch	500 mm 19.68 inch	300 mm 11.81 inch